

IPANIPAN , by PowerSurface.nl

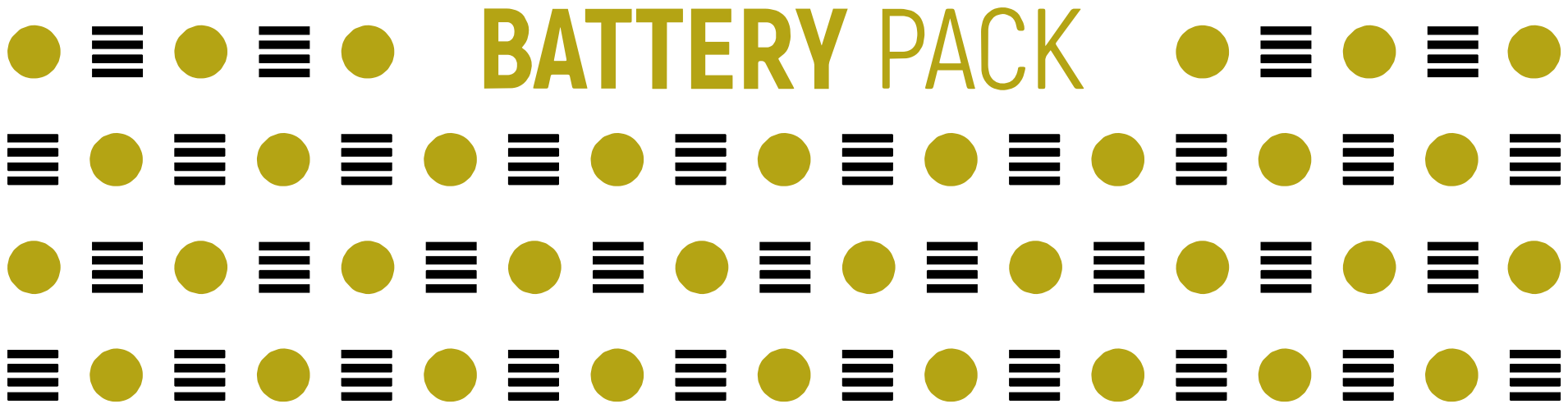

www.powersurface.nl



info@powersurface.nl



MAKE EVERY SURFACE A POWER SOURCE

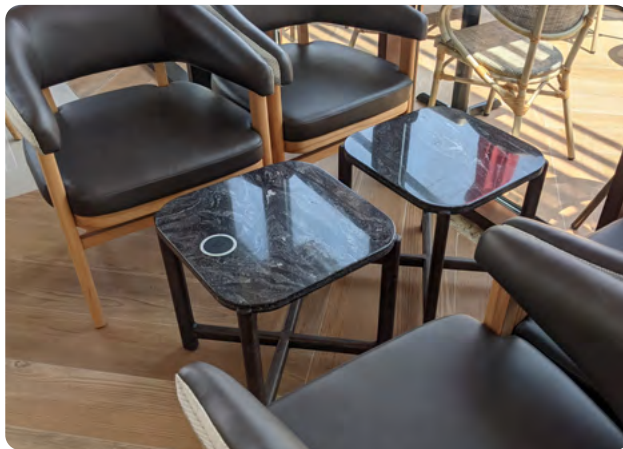

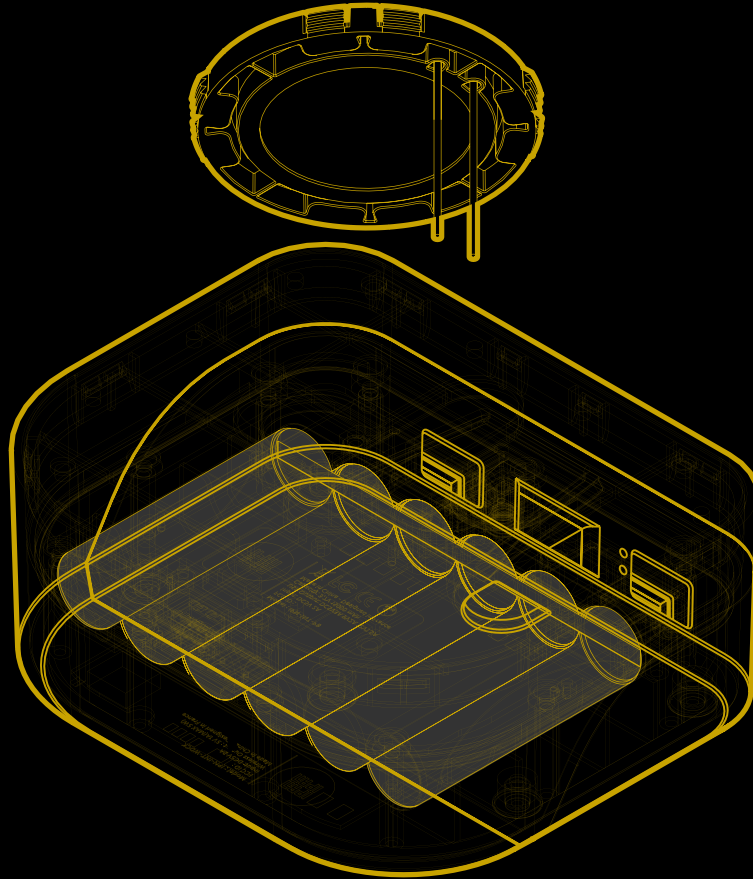

IPAN IPAN

MAKE EVERY SURFACE A POWER SOURCE

IPAN IPAN is a french company specialized in **wireless charging for public places** since 2011.

It develops, **designs and manufactures** its wireless charging solutions for the **furniture industry**, hospitality market and professional installers.

As an active member of the **Wireless Power Consortium (WPC)**, IPAN IPAN offers Qi certified solutions in order to guarantee the **highest safety and quality level** to its customers and users.

IPAN IPAN **innovates** to provide state-of-the-art wireless charging solutions in line with the **constantly evolving clients' requirements**.



01	PRESENTATION	5
	• Charging service : need ? opportunity !	
	• Product overview	
	• Integrations	
02	TECHNICAL DESCRIPTIONS	20
	• Embedded Pack	
	• Flat Pack	
	• On Top Pack	
	• USB Pack	
	• Tutorials vidéos	
03	CATALOGUE	26
	• Packages	
	• Products (Metal sticker/ Battery/Magnetic security key/Charging tray)	





01 | BATTERY PACK
PRESENTATION



CHARGING SERVICE : NEED ? OPPORTUNITY !





CHARGING NEED IN PUBLIC PLACES

2/3
CUSTOMERS

WANT TO CHARGE
THEIR PHONE IN HoReCa

HAVE ALREADY COME ONLY
TO CHARGE THEIR PHONE

17%
CUSTOMERS



NEED
TO STAY
CONNECTED



**BOOST
FREQUENTATION
OF YOUR BUSINESS**

WHY TO PROVIDE CHARGING SERVICE

IMPROVE
**CUSTOMER
SATISFACTION**



**INCREASE THE INCOME
OF YOUR BUSINESS**



**DIFFERENTIATE YOURSELF
FROM THE COMPETITION**





BATTERY PACK

PRODUCT OVERVIEW

UNIVERSAL CHARGING STATION

FEATURES



AUTONOMOUS

FEATURES

NO ELECTRICAL OUTLET



UP TO 8 DAYS OF AUTONOMY



15 Ah BATTERY



OUTDOOR RESISTANT

FEATURES

SHOCK PROOF

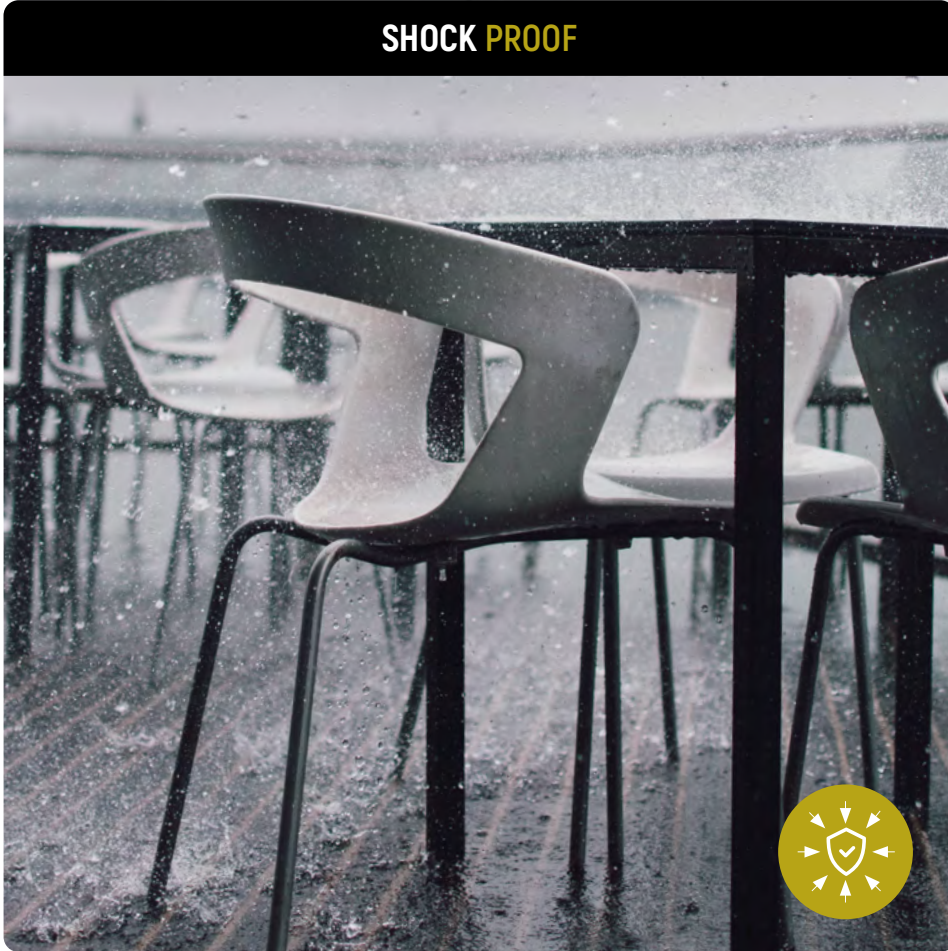

IP 65 CERTIFIED



SECURE LOCKING

FEATURES

ANTI-THEFT SYSTEM



MAGNETIC SECURITY KEY



CHARGING TRAY

FEATURES

FULL LOAD 7 HOURS



BATTERIES CHARGER



The background of the entire image is a solid yellow color. Overlaid on this background is a grid of small, light-yellow geometric shapes. The shapes alternate in a checkerboard pattern between circles and squares. Each shape is composed of three horizontal lines, giving them a stylized, segmented appearance. The grid covers most of the page, with the text centered in the middle.

BATTERY PACK

INTEGRATIONS



Marking on
the surface

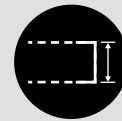

Top thickness
to 12 from 80 mm

EMBEDDED

INTEGRATED WIRELESS CHARGING STATION

Integrated into the mass and invisible on surface, the charging areas merge with the decor using a simple marking on the table top. This ensures the furniture keeps its integrity, giving a perfect smooth touch and refined design.

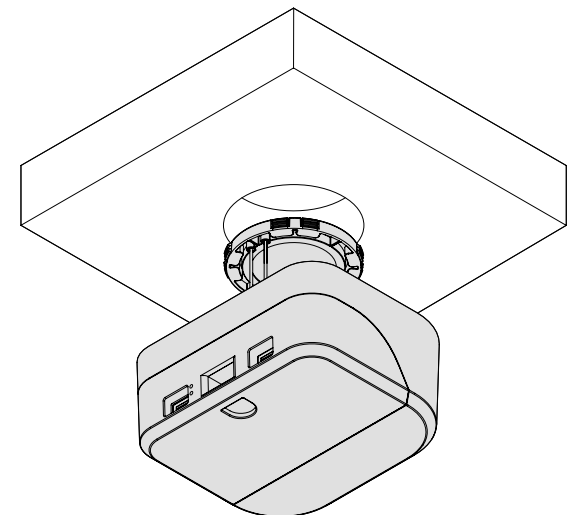



Flat
designed

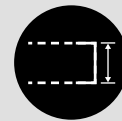

Top thickness
from **8** to **60 mm**

FLAT

PERFECT SMOOTH FINISH ON SURFACE

Perfect condensed between design and sobriety, the FLAT charging stations are integrated into the table tops' surface to live in perfect harmony with the furniture. These charging stations create a totally flat appearance with the best level of finish that has never been achieved before.

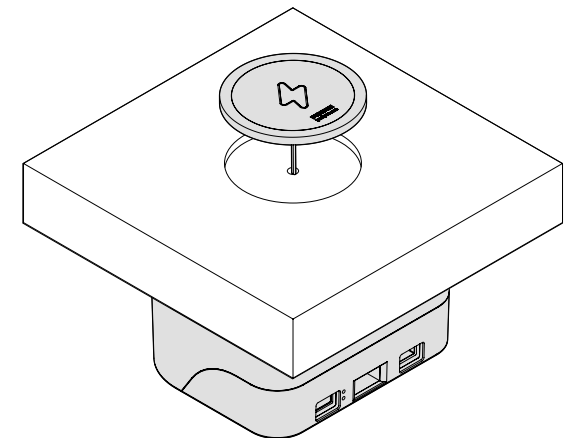



Installation
in 5 mins



1 single hole
of 3mm min.

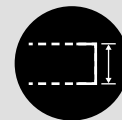

Top thickness
from 8 to 55 mm

ON TOP

UNIVERSAL EASY TO INSTALL SOLUTION

The ON TOP by IPAN IPAN charging stations combine slimness and robustness and can be easily and quickly installed on table tops thanks to their adhesive fixing system. The clear aluminium design allows the charging areas to be identified quickly.

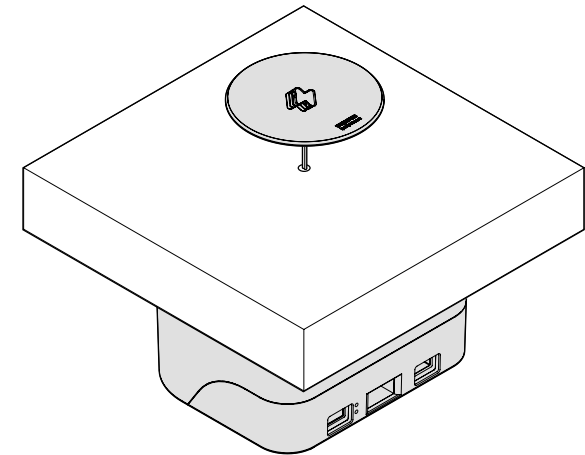

PACK USB ONLY



Installation
in 5 mins



Fast charge
up to 15W delivered



Adhesive fastening
ultra-resistant

USB

CHARGE BY USB – PLUG AND PLAY VERSION

The first autonomous & secure USB charging station. With the USB pack, the charging unit can be easily installed under any table without any machining on the table top.

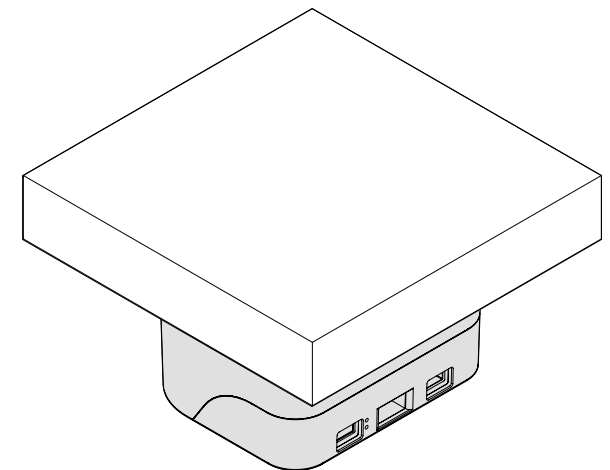



02

BATTERY PACK

TECHNICAL DESCRIPTIONS

EMBEDDED PACK

INTEGRATION PLAN

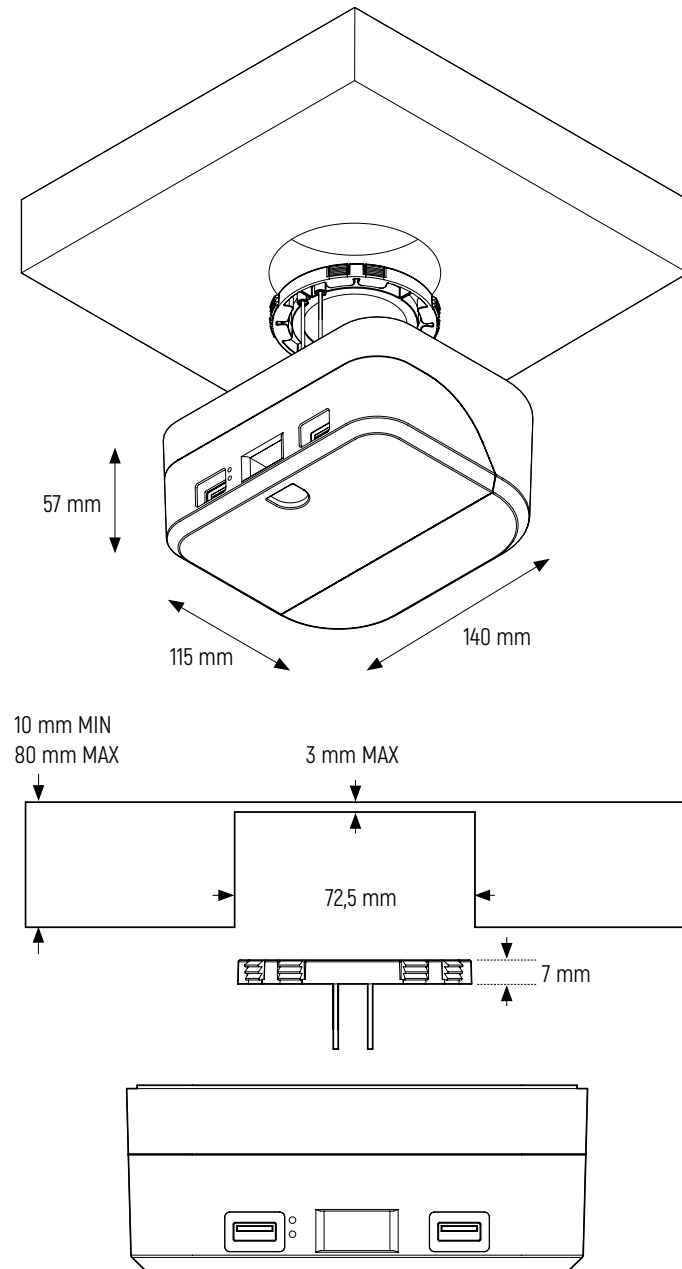

FLAT PACK

INTEGRATION PLAN

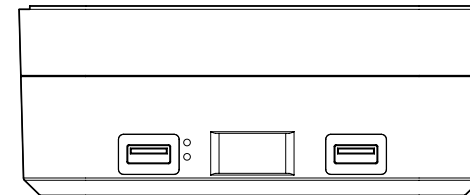
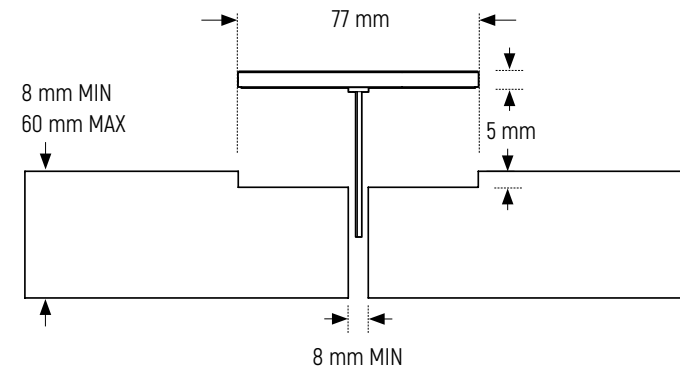
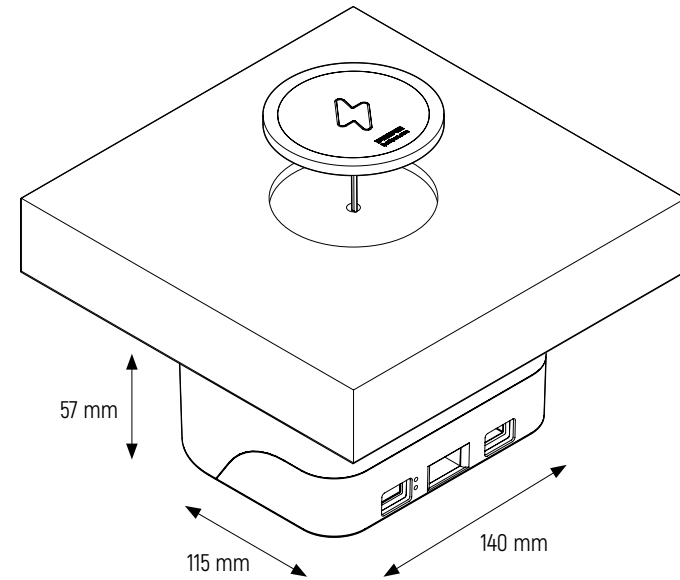

ON TOP PACK

INTEGRATION PLAN

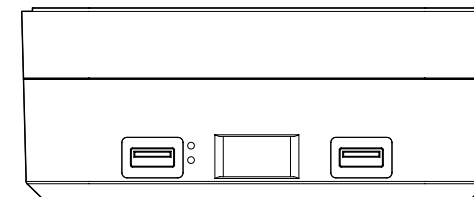
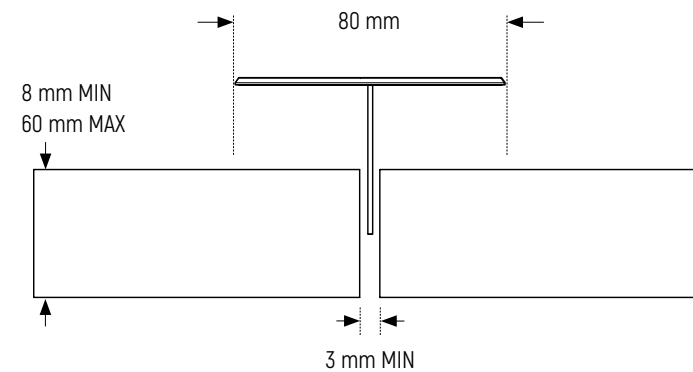
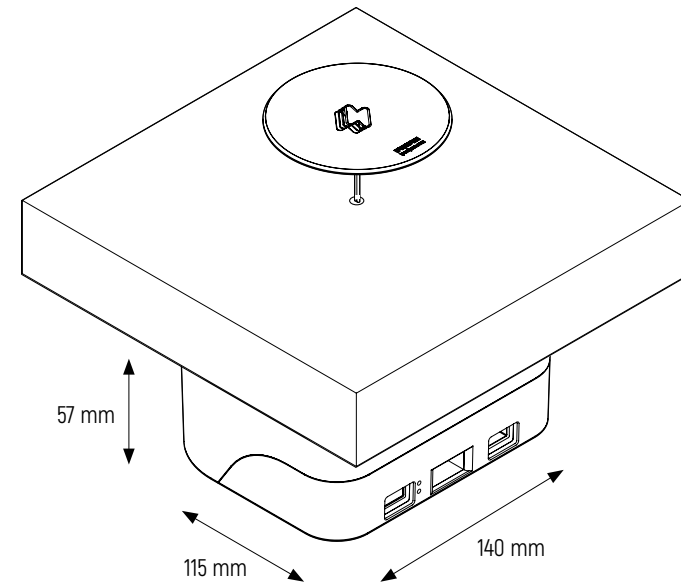

USB PACK

INTEGRATION PLAN

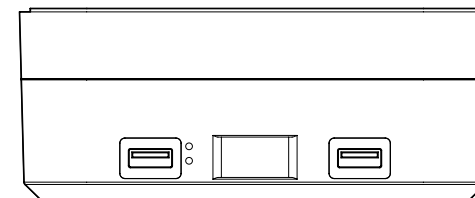
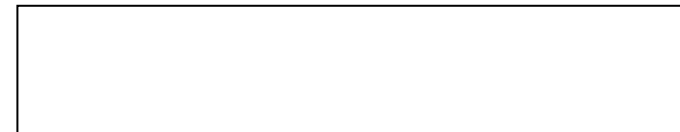
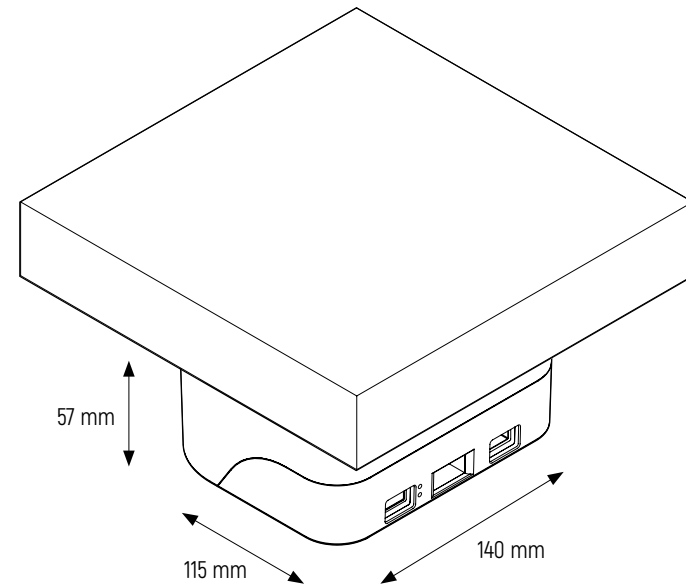

TUTORIALS

VIDÉOS



INSTALLING THE EMBEDDED PACK



INSTALLING THE FLAT PACK



INSTALLING THE ON TOP PACK



INSTALLING THE USB PACK



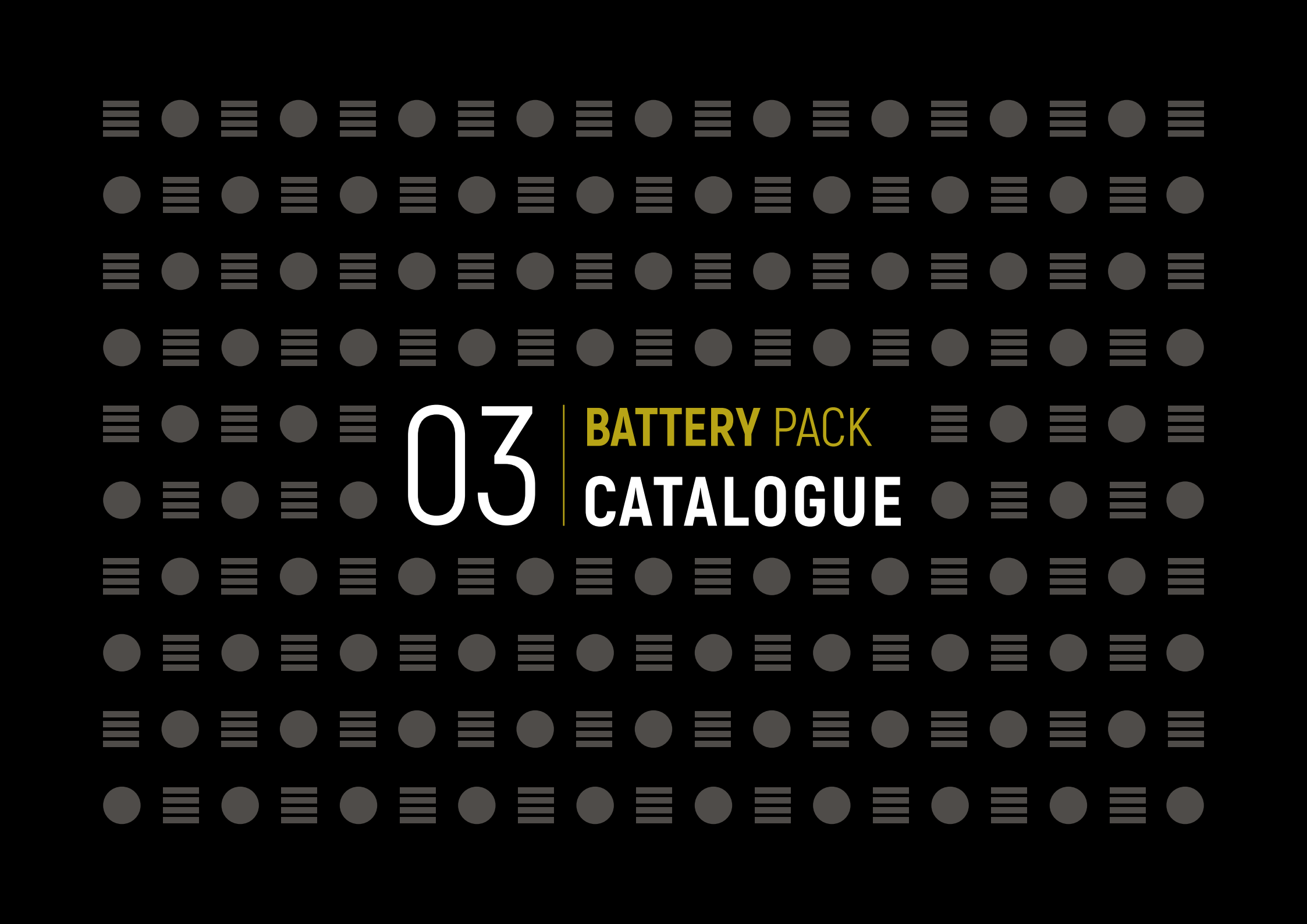

03 | **BATTERY PACK**
CATALOGUE

EMBEDDED PACK

IPN-WCPB-EMB

DESCRIPTION

A battery charger for phones and other mobile devices, which is fitted in the furniture. The Embedded antenna is housed in a cavity under the furniture top. The furniture maintains its original appearance. Marking the surface of the top is required.

Contenu du Pack :

- Embedded antenna
- 1 wireless charger and 2 USB ports
- Battery included [55,5 Wh]
- Safe : overheating, overcurrents, overvoltages and short circuits.



OVER-CURRENT
PROTECTION



OVER-HEAT
PROTECTION



OVER-VOLTAGE
PROTECTION



SHORT CIRCUIT
PROTECTION

NB : The magnetic security key and the charging tray are not included in the pack.

Designed in France

FCC ID : 2A06R-IPN-WDCK

CERTIFICATIONS

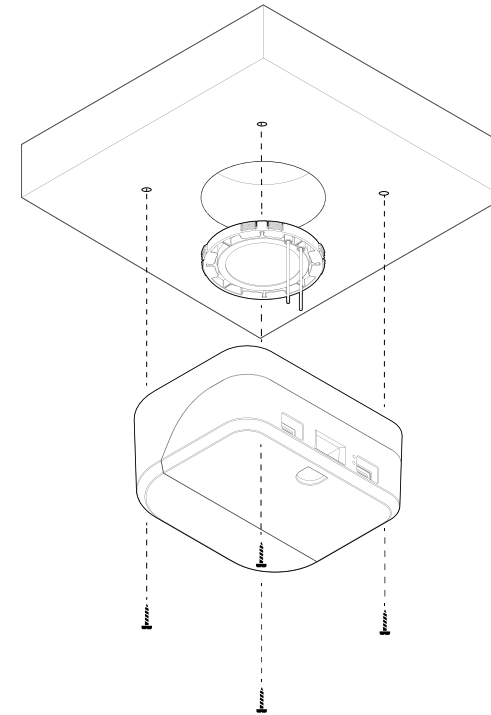

FLAT PACK

IPN-WCPB-FLT

DESCRIPTION

A battery charger for phones and other mobile devices, which is fitted in the furniture. The Flat antenna is embedded in the top surface for a completely flat finish. It is waterproof and UV resistant.

Contents of the Pack:

- Flat antenna
- 1 wireless charger and 2 USB ports
- Battery included (55,5 Wh)
- Safe : overheating, overcurrents, overvoltages and short circuits.



NB : The magnetic security key and the charging tray are not included in the pack.

Designed in France
FCC ID : 2A06R-IPN-WDCK

CERTIFICATIONS

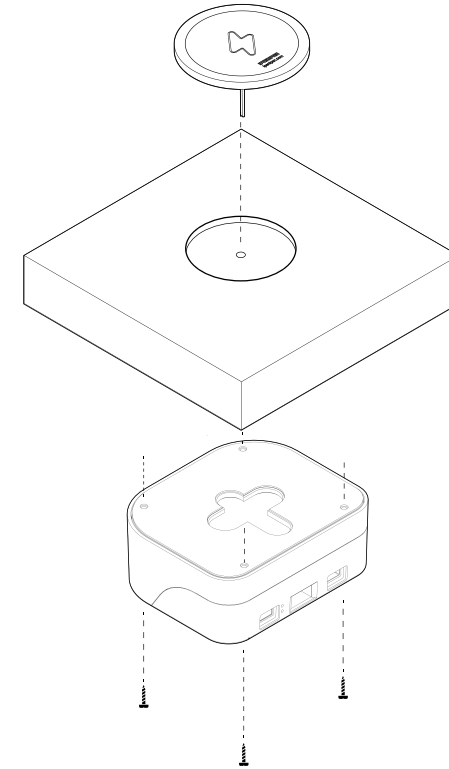

ON TOP PACK

IPN-WCPB-OTP

DESCRIPTION

A battery charger for phones and other mobile devices that can be quickly attached to all types of furniture thanks to its ultra-resistant adhesive. The On Top antenna is installed in a drill hole. It is waterproof and UV resistant. Its aluminium finish highlights the charging area while combining finesse and robustness.

Contents of the Pack:

- On top antenna
- 1 wireless charger and 2 USB ports
- Battery included (55,5 Wh)
- Safe : overheating, overcurrents, overvoltages and short circuits.



NB : The magnetic security key and the charging tray are not included in the pack.

Designed in France

FCC ID : 2A06R-IPN-WDCK

CERTIFICATIONS

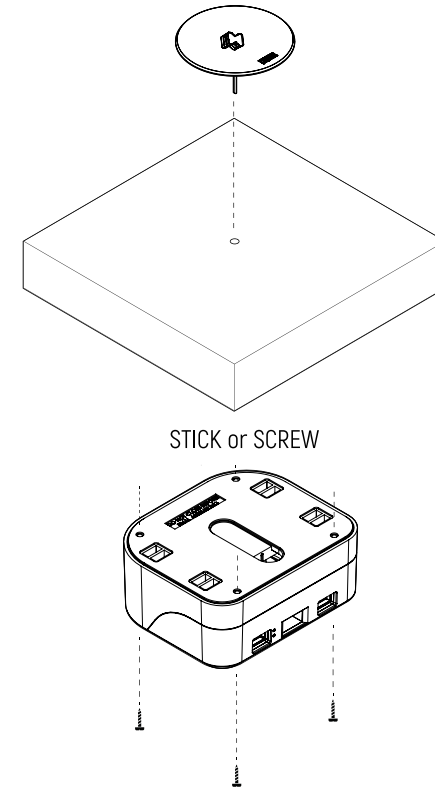

USB PACK

IPN-INT-PBUSB

DESCRIPTION

The first battery-powered USB charger for phones and other mobile devices that attaches to any furniture surface in less than a minute thanks to its ultra-resistant adhesive attachment. Stick and charge!

Contents of the Pack:

- 2 USB fast charging sockets.
- Battery included (55,5 Wh)
- Safe : overheating, overcurrents, overvoltages and short circuits.



OVER-CURRENT
PROTECTION



OVER-HEAT
PROTECTION



OVER-VOLTAGE
PROTECTION



SHORT CIRCUIT
PROTECTION

NB : The magnetic security key and the charging tray are not included in the pack.

Designed in France

FCC ID : 2A06R-IPN-WDCK

CERTIFICATIONS



FC

CE



RoHS

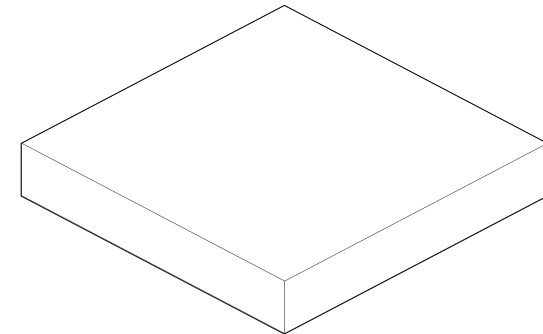

STICK or SCREW

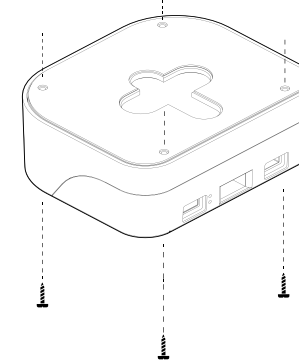

METAL STICKER

IPN-INT-EMB-MS

DESCRIPTION

The Metal sticker is used to mark the charging area of a top equipped with the Embedded antenna. It is larger than the antenna to avoid any problem of metallic interference with the station of charging area. It is made of aluminum to avoid any problem of corrosion. It is laser marked. Its thickness is only 0.2mm to make it imperceptible to the touch. It is equipped with ultra-powerful adhesive which allows it to be used indoors as well as outdoors

NB : The marking of the Metal sticker is customizable on MOQ.

Designed in France

CERTIFICATIONS

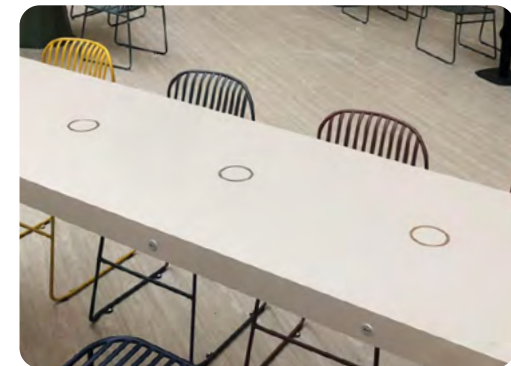
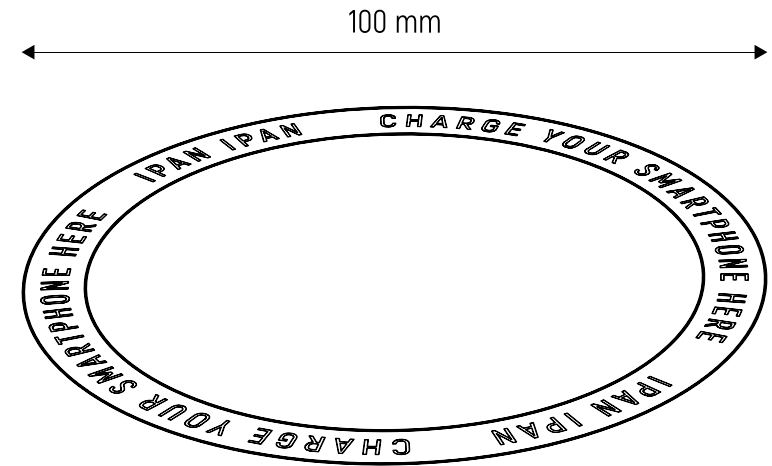

BATTERY 15Ah

IPN-INT-PB

DESCRIPTION

Battery with a capacity of 15 Ah which powers the Battery Pack. It is fitted with a magnetic lock. It recharges in the Charging tray.

- Magnetic locking
- Water resistance certified IP 65
- Quick charge. Output : DC 5V 3A/9V 2A/12V 1.5A
- Safe : overheating, overcurrents, overvoltages and short circuits.



Designed in France

FCC ID : 2A06R-IPN-WDCK

CERTIFICATIONS

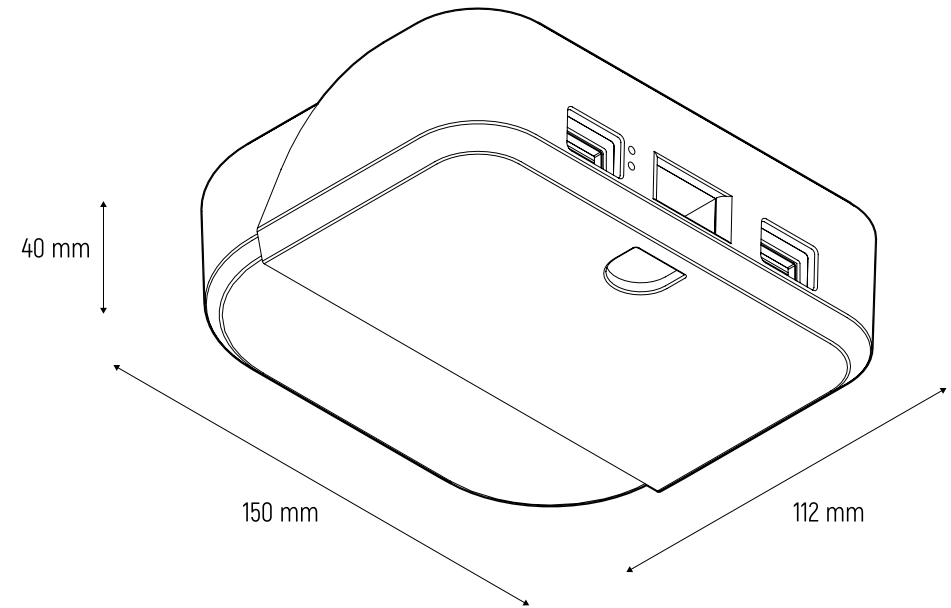

MAGNETIC SECURITY KEY

IPN-INT-KEY-R

DESCRIPTION

The Magnetic Security Key is a handle which allows for unlocking and removal of the battery from the Battery Pack attached to the underside of the table. It is equipped with a magnetic lock system. By its design, it allows quick and easy removal of the battery and of the Battery Pack without having to lean under the table.

Designed in France

CERTIFICATIONS

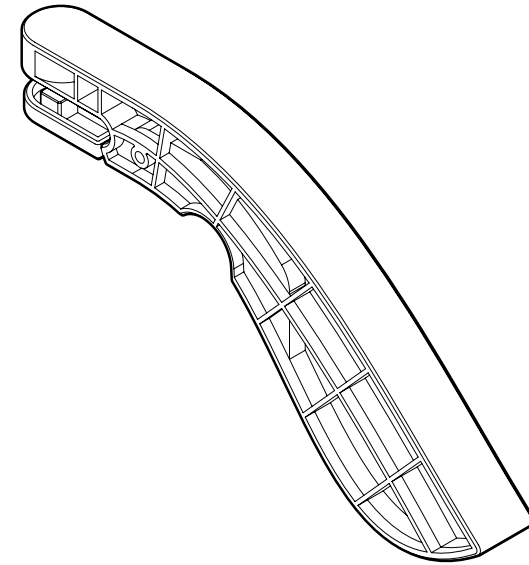

CHARGING TRAY

IPN-INT-CT-EU

IPN-INT-CT-UK

IPN-INT-CT-US

DESCRIPTION

The Charging tray allows you to recharge the batteries of the Battery Pack. Up to 4 batteries simultaneously in 7 hours.

- 4 charging slots
- ACDC (40W max) available in EU, UK and US versions

Designed in France

FCC ID : 2A06R-IPN-WDCK

CERTIFICATIONS

